



**LOW OHM POWER
RESISTORS**

**HEE
SERIES
Size 5930**

- Open frame electron beam welded punched out type.
- Power Rating at 100°C - upto 10W
- Power Rating at 70°C - upto 15W
R0001 to R002





LOW OHM
POWER
RESISTORS
HEE
SERIES
Size 5930

PHYSICAL CONFIGURATION

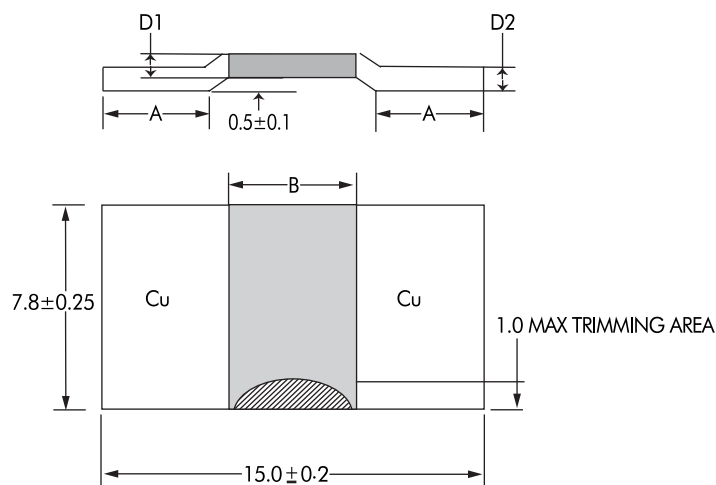

DIMENSIONAL TABLE

SR NO.	HTR TYPE	RESISTANCE VALUE	TOLERANCE	WATTAGE AT 100° C	WATTAGE AT 70° C	A (mm) +0.1/-1.0	B (mm) +0.2/-0.3	D1 (mm) ± 0.10	D2 (mm) ± 0.10	INTERNAL HEAT RESISTANCE (Rthi)	TCR (ppm)	TYPICAL WT. PER PC (gms)
1	HEE10W R0001	R0001	± 0.25, ± 0.5, ± 1, ± 2, ± 3, ± 5%	10W	15W	4.2	3.7	1.42	1.42	2° K/W	< 200	1.65
2	HEE10W R0002	R0002	± 0.25, ± 0.5, ± 1, ± 2, ± 3, ± 5%	10W	15W	4.2	5.0	1.40	1.40	3° K/W	< 100	1.60
3	HEE7W R0003	R0003	± 0.25, ± 0.5, ± 1, ± 2, ± 3, ± 5%	7W	10W	4.2	5.0	0.93	0.93	4.5° K/W	< 100	1.10
4	HEE7W R0005	R0005	± 0.25, ± 0.5, ± 1, ± 2, ± 3, ± 5%	7W	10W	4.2	4.4	1.63	1.42	5° K/W	< 75	1.62
5	HEE6W R0005	R0005	± 0.25, ± 0.5, ± 1, ± 2, ± 3, ± 5%	6W	8W	4.2	5.0	0.55	0.55	8° K/W	< 75	0.61
6	HEE5W R0006	R0006	± 0.25, ± 0.5, ± 1, ± 2, ± 3, ± 5%	5W	8W	4.2	5.0	0.46	0.46	10° K/W	< 75	0.53
7	HEE6W R001	R001	± 0.25, ± 0.5, ± 1, ± 2, ± 3, ± 5%	6W	9W	4.2	4.9	0.91	0.91	8° K/W	< 50	0.90
8	HEE4W R002	R002	± 0.25, ± 0.5, ± 1, ± 2, ± 3, ± 5%	4W	7W	4.2	4.9	0.46	0.70	16° K/W	< 50	0.44

APPLICATIONS

- Accurate current sensing for power hybrid applications.
- Suitable for welding on bus bars.
- High current applications for automotive market.
- Frequency converters.
- Power modules.

FEATURES

- 10W constant power possible in R0002.
- Capable of carrying current upto 225amp (R0002) continuous basis.
- Sturdy copper connectors.
- Excellent long term stability.
- Maximum solder temperature upto 350°C for 30 seconds.



LOW OHM
POWER
RESISTORS
HEE
SERIES
Size 5930

ELECTRICAL AND ENVIRONMENTAL CHARACTERISTICS

PARAMETER / PERFORMANCE TEST & TEST METHOD	PERFORMANCE REQUIREMENTS
Power Rating	For FeCrAl - Full power dissipation at 70° C and linearly derated to zero at +170° C. For Manganin (< 0.5% Improved Stability) - Full power dissipation at 90° C & linearly derated to zero at +140° C. For Manganin (< 1% Stability) - Full power dissipation at 120° C and linearly derated to zero at +170° C.
Inductance	< 3nH
Temperature Range	- 55° C to +170° C
Voltage Rating / Limiting Voltage / Max. Working Voltage (Subject to max. Terminal Temperature of 120° C)	$\sqrt{P \times R}$
Low Temperature Storage and Operation [-65° C for 250 h]	$\Delta R \pm 0.1\%$ - Average
Temperature Coefficient of Resistance (Ambient Temperature Range 20° C - 60° C)	From 50 ppm / K (Depending on Resistance Value)
Temperature Cycling -2000 cycles (-55° C to 150° C)	$\Delta R \pm 0.5\%$ - Average
Life Test / Operational Life - 2000 h rated power with Temperature limitation on Terminal kept at 120° C	$\Delta R \pm 1\%$ - Average
Moisture Resistance [MIL-STD-202 method106]	$\Delta R \pm 0.1\%$ - Average
Mechanical Shock [100 g. 6 ms half sine]	$\Delta R \pm 0.2\%$ - Typical
Vibration, High Frequency [20 g. 10-2000 Hz]	$\Delta R \pm 0.2\%$ - Typical
Bias Humidity [+85° C, 85% RH, 1000h]	$\Delta R \pm 0.5\%$ - Typical
Resistance to Soldering Heat	260° C for 10 sec / 8h steam aging
High Temperature Exposure – 2000h / 170° C	$\Delta R \pm 1\%$ - Average (In covered condition)

RECOMMENDED SOLDER PROFILE

Reflow, IR - and wave soldering			
Temperature (°C)	260	255	217
Time (Sec)	Peak	40	90

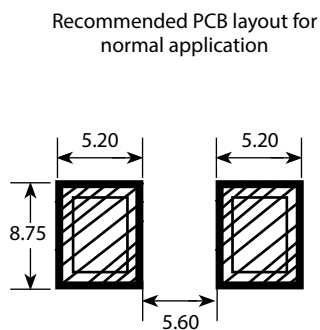
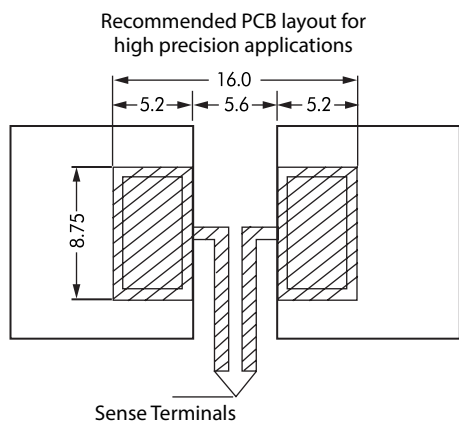

TYPICAL POWER DERATING CURVE FOR RESISTOR WHEN FULL POWER IS AT 90°C & 120°C

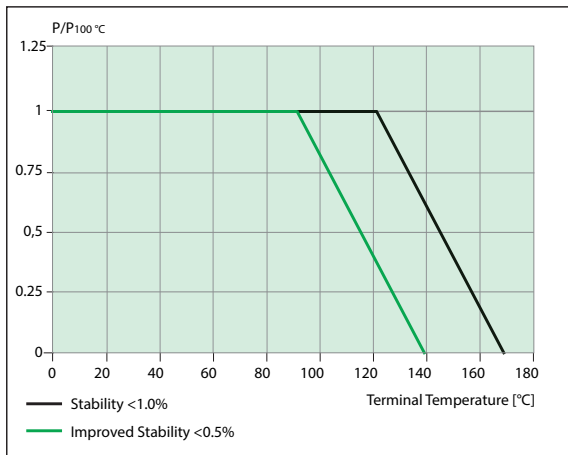

TYPICAL POWER DERATING CURVE FOR RESISTOR WHEN FULL POWER IS AT 70°C

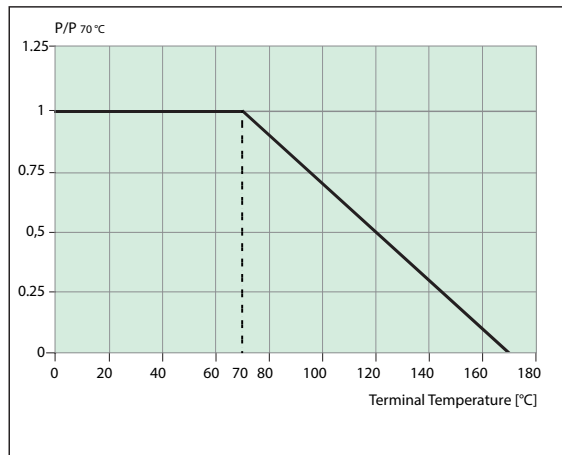

In case the Design Engineer requires a specific graph of a particular component it can be supplied on request.

MAXIMUM PULSE ENERGY WITH RESPECT TO PULSE POWER FOR PERMANANT OPERATION

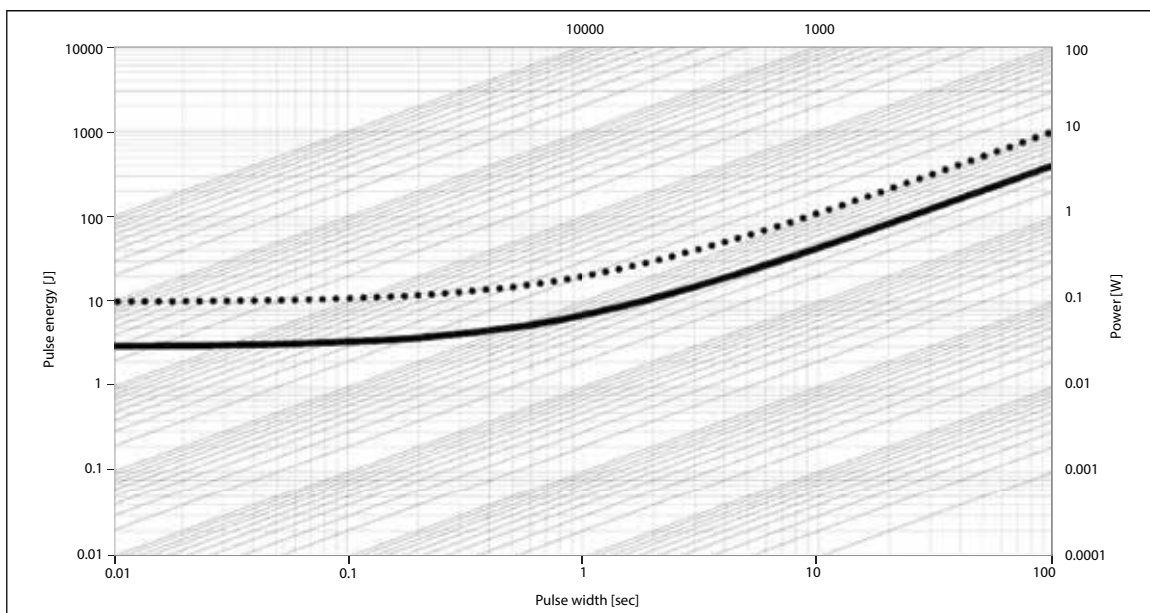

In this graph the max. & min. curve are shown as ••• and — for all resistance values, the area between the max. & min. curve is applicable. In case the Design Engineer requires a specific graph of a particular component it can be supplied on request.

TYPICAL TEMPERATURE DEPENDANCE OF THE ELECTRICAL RESISTANCE

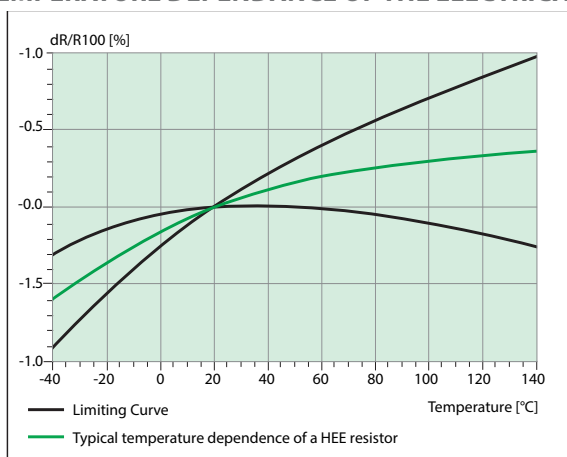



LOW OHM
POWER
RESISTORS
HEE
SERIES
Size 5930

PACKAGING

A. BULK

Resistors shall be packed in the plastic Box-K-44 of approximate size 162mmx104mmx37mm - 1500 pcs/box and this box will be vacuum sealed with polythene of 100 micron. With enclose silica gel.

B. TAPE & REEL PACKING

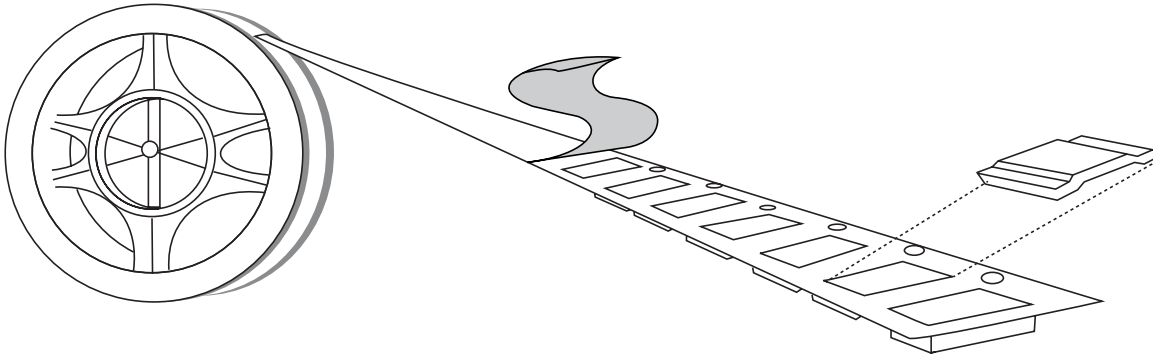

SPECIFICATION	TAPEWIDTH	PARTS PER REEL
EIA-481-D	24mm	2000 pcs

STORAGE CONDITION

Shelf Life (packed) : Temp 25°C to 35°C, Humidity 30 to 80% RH, Shelf life-12 months floor

Floor Life (unpacked) : Temp 25°C to 35°C, Humidity 30 to 80% RH, Floor life-15 days

ORDERING INFORMATION AS AN EXAMPLE

SERIES	HTR PART NO.	TYPE	RESISTANCE VALUE	TOLERANCE	MARKING ON RESISTOR
HEE	HEE6W	Tape & Reel – HEE6WTR	R001	± 1%	HTR HEE R001 1% DATECODE
HEE	HEE7W	Bulk - HEE7W	R0005	± 0.5%	HTR HEE R0005 0.5% DATECODE
HEE	HEE10W	Tape & Reel – HEE10WTR	R0001	± 5%	HTR HEE R0001 5% DATECODE

Part no of HEE6W, Tape and reel with resistance value R001 and 1% tolerance, will be **HEE6WTR R001 ±1%**

Part no of HEE7W, Bulk with resistance value R0005 and 0.5% tolerance, will be **HEE7W R0005 ±0.5%**

Part no of HEE10W, Tape and reel with resistance value R0001 and 5% tolerance, will be **HEE10WTR R0001 ±5%**