



Manufactured in line with the requirements of MIL 18546 and IEC 115, designed for direct heatsink mounting with thermal compound to achieve maximum performance.

ALUMINIUM HOUSED POWER RESISTORS

HAH SERIES

- Excellent Electrical stability, reliability and mechanically very rigid
- Non Inductive version available
- Values from R01 to 100K
- Custom termination, Mounting arrangements available.

As per AEC-Q200





ALUMINIUM
HOUSED
POWER
RESISTORS
HAH
SERIES

PHYSICAL CONFIGURATION (HAH10-HAH300)

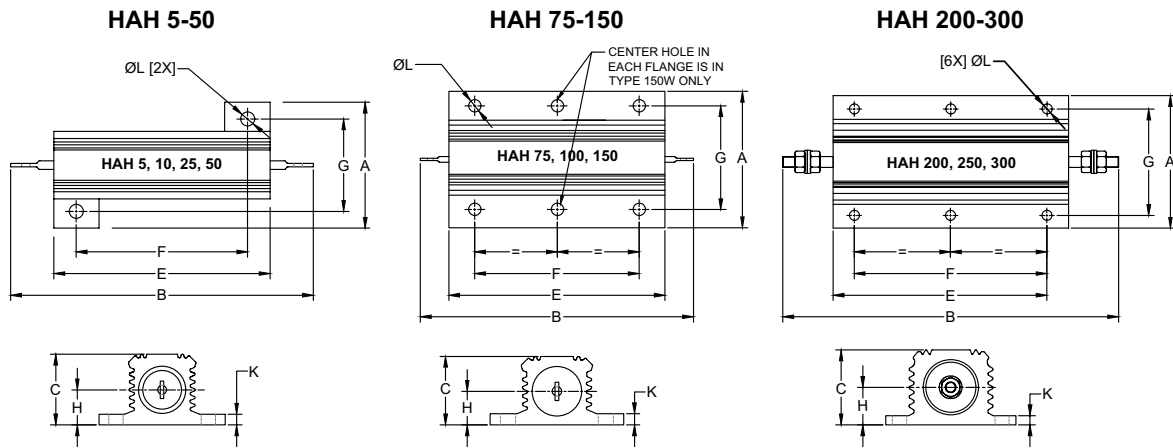

DIMENSIONAL TABLE (mm)

Type	E ±0.5	B max	A max	F±0.3	G ±0.3	Ø L ±0.5	H max	C max	K max
HAH5	16.8	31.0	17.0	11.3	12.4	2.4	4.5	9.0	1.7
HAH10	20.1	36.5	21.0	14.3	15.9	2.4	5.5	11.0	2.0
HAH25	27.3	52.0	28.0	18.3	19.8	3.2	7.5	15.0	2.0
HAH50	50.1	72.5	30.0	39.7	21.4	3.3	8.5	17.0	2.5
HAH75	48.9	71.0	48.0	29.0	37.0	4.4	12.0	23.5	3.5
HAH100	65.4	87.5	48.0	35.0	37.0	4.4	12.0	23.5	3.5
HAH150	97.0	122.0	48.0	58.0	37.0	4.4	12.0	23.5	3.5
HAH200	89.0	143.0	72.0	70.0	57.2	5.5	20.5	45.0	5.0
HAH250	114.0	163.0	72.0	89.0	57.2	5.5	20.5	45.0	5.0
HAH300	127.0	180.0	72.0	104.0	59.0	6.5	20.5	45.0	5.0

ELECTRICAL SPECIFICATIONS

Type	Rated power on heatsink @25°C (w)	Rated power W/O heatsink @25°C (w)	Resistance range (Ω)	Max working voltage (DC/AC rms) (V)	Dielectric strength (AC peak)	Weight (gms approx.)	Standard heatsink area (cm ²)	Standard heatsink thickness (cm ²)
HAH5	10	5	R10 - 10K	160	1000	5	400	0.1
HAH10	15	8	R10 - 15K	260	1000	7	400	0.1
HAH25	25	12.5	R01- 33K	550	1800	15	550	0.1
HAH50	50	20	R01- 100K	1250	1800	30	550	0.1
HAH75	75	45	R10- 50K	1400	3600	85	1000	0.3
HAH100	100	50	R10 - 100K	1900	3600	115	1000	0.3
HAH150	150	55	R10 - 100K	2500	4000	175	1000	0.3
HAH200	200	50	R10 - 50K	1900	5000	475	3750	0.3
HAH250	250	60	R10 - 65K	2200	5000	600	4800	0.3
HAH300	300	75	R10 - 80K	2500	5000	700	5800	0.3



ALUMINIUM
HOUSED
POWER
RESISTORS
HAH
SERIES

POWER DERATING CURVE

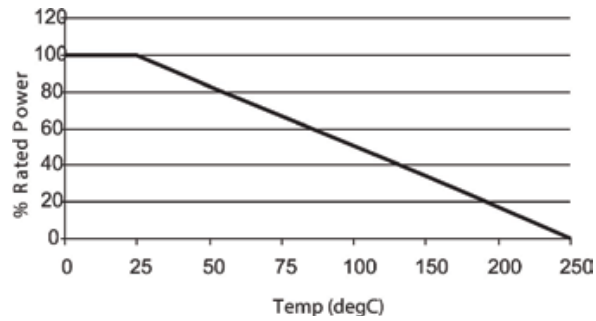

ELECTRICAL AND ENVIRONMENTAL CHARACTERISTICS

PARAMETER / PERFORMANCE TEST & TEST METHOD	PERFORMANCE REQUIREMENTS
Tolerance (Code)	Standard $\pm 5\%$ (J) Also available $\pm 0.25\%$ to $\pm 5\%$
Temperature coefficients	100 ppm / °C max
Insulation resistance (Dry)	10 G Ω
Endurance (1.5Hrs ON, 0.5Hrs OFF for 1000Hrs @Room Temperature)	$\Delta R < 1\% +0R05$
Short Term Overload (5 x Rated Power or Isolation Voltage (Whichever is Lesser of the two Voltages))	$\Delta R < 1\% +0R05$
Termination Robustness (20N Tensile Force)	$\Delta R < 0.25\% +0R05$
Resistance to Soldering Heat (260°C, 10 Seconds)	$\Delta R < 0.25\% +0R05$
Rapid Change of Temperature (-55°C/200°C, 5 Cycles)	$\Delta R < 0.25\% +0R05$
Bump (4000 Bumps at 40g)	$\Delta R < 0.25\% +0R05$
Vibration (10Hz to 500Hz, 10g, 6hrs)	$\Delta R < 0.25\% +0R05$

HEAT DISSIPATION

Whilst the use of proprietary heat sinks with lower thermal resistances is acceptable, uprating is not recommended. For maximum heat transfer it is recommended that a heat sink compound be applied between the resistor base and heat sink chassis mounting surface. It is essential that the maximum hot spot temperature of 200°C is not exceeded, therefore, the resistor must be mounted on a heat sink of correct thermal resistance for the power being dissipated.

ORDERING INFORMATION

SERIES	TYPE	PACKING	RESISTANCE VALUE	TOLERANCE	MARKING
HAH	HAH10	BULK	100R	J (5%)	HTR LOGO HAH10 100R J Date Code